

Source: Leece-Neville Heavy Duty Systems Division -
Arcade, NY USA
Date: February 28, 2006
Subject: Replacement of 8RL3021, 8RL3022 with 8RL3024
Bulletin No: TSB-1041
Models: 8RL3021, 8RL3022, 8RL3024

Technical Service
Bulletin

Replacement of 105-351 (8RL3021) and 105-352 (8RL3022) with 105-396 (8RL3024)

Redesign of the 105-351 and 105-352 was done to incorporate a sealed regulator housing to improve the reliability of the regulator. This redesign also allowed us to integrate the below enhancements along with offering a common regulator for multiple alternators as noted below:

- a. The adjustment potentiometer was removed to eliminate the possibility of improper adjustments by the user.
- b. Two regulators, the 105-351 “three wire regulator” and the 105-352 “four wire regulator”. The new 105-396 regulator is compatible with both configurations. To demonstrate these conditions, the two alternator/regulator configurations are shown below:

The following alternators (110-302, 110-258A, 110-316, 110-431, 110-569) referred to as **ALTERNATOR A** used a three wire regulator (105-351). The D+ signal is connected directly to the positive side of the field (F+) inside the alternator. In this configuration, the red lead from the 105-396 regulator is not used and is connected to an unused terminal.

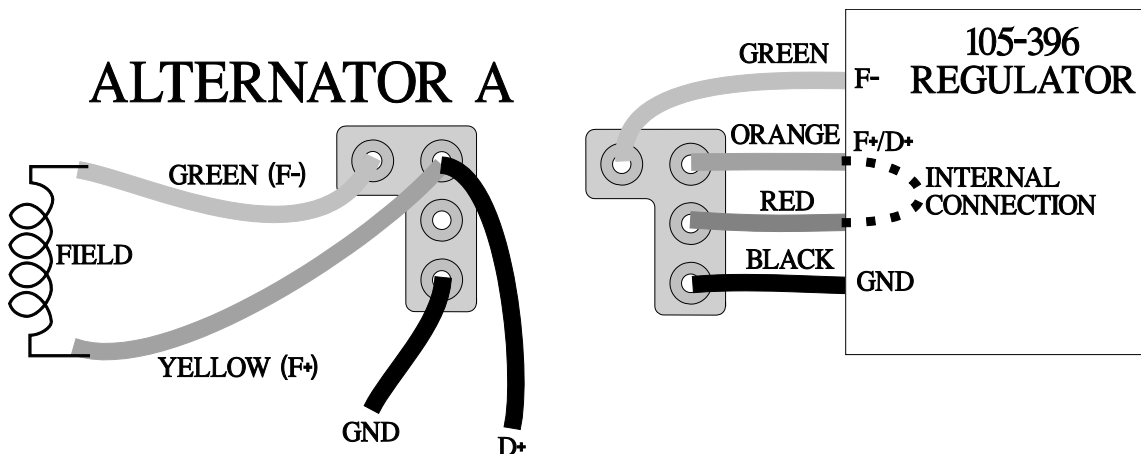

Important: The information contained in this bulletin is intended for use by trained, professional technicians who have the proper tools, equipment, and training to perform the required maintenance described above. This information is NOT intended for 'do-it-yourselfers', and you should not assume that this information applies to your equipment. If you have any questions regarding this information please visit our website at www.prestolite.com, or contact our technical service department at:

Bulletin No.: TSB-1041

Technical Service
 Bulletin

This alternator (110-298) referred to as **ALTERNATOR B** originally utilized the four wire regulator (105-352). The internal wiring of this alternator and regulator has not changed.

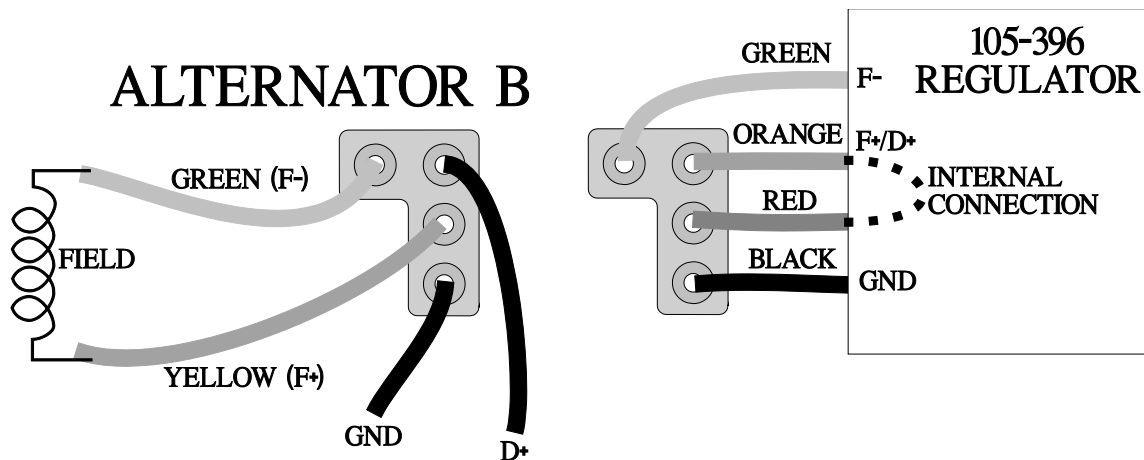

When installing the new regulator, use the following torques:

Terminal nuts (4)	4-7	in. lb.
Mounting screws (4)	28-33	in. lb.
Excitation nut (1)	25-30	in. lb.

If Alternator does not function properly after installing new regulator, verify proper internal wiring of alternator and verify Excitation Voltage is properly connected.

Important: The information contained in this bulletin is intended for use by trained, professional technicians who have the proper tools, equipment, and training to perform the required maintenance described above. This information is NOT intended for 'do-it-yourselfers', and you should not assume that this information applies to your equipment. If you have any questions regarding this information please visit our website at www.prestolite.com, or contact our technical service department at: