

Source: Leece-Neville Heavy Duty Systems Division - Arcade, NY USA  
 Date: June 27, 2017  
 Bulletin No: TSB-1006  
 Models: Replacing 8EM3005CA with 8MR3005C  
 Subject: 8EM to 8MR Wiring Instructions

**Wiring Instructions**  
**Alternator Installation Instructions**

**Model No. 8MR3005C**  
**Replacing 8EM3005CA**

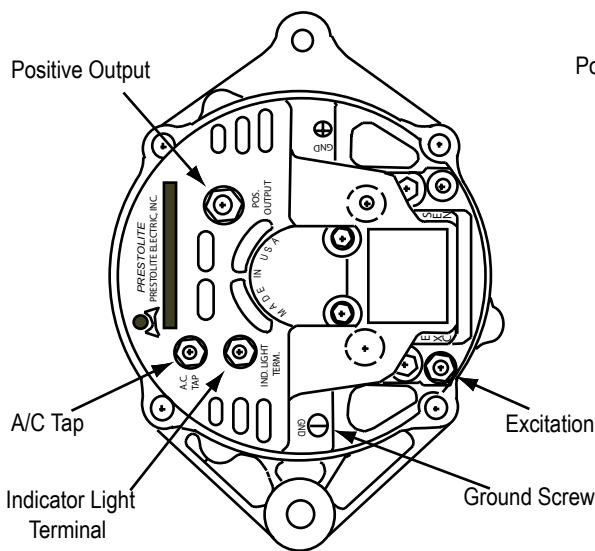

**Original 8EM3005CA**

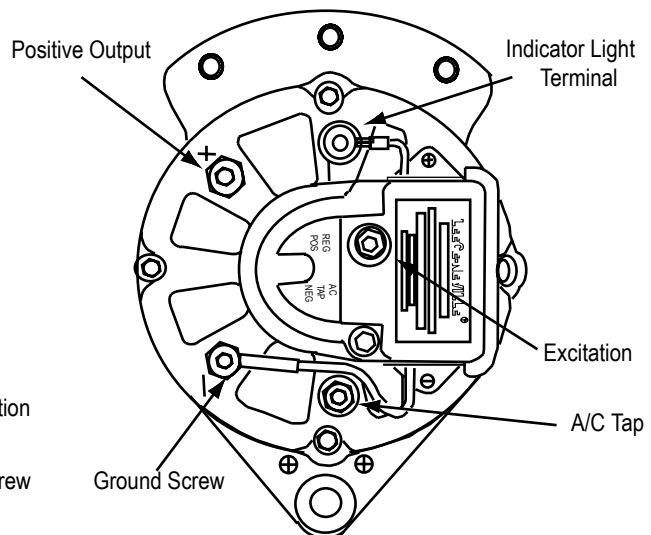

**New 8MR3005C**

**NOTICE:** The rear housing on the 8MR3005C is rotated 180 degrees from the 8EM3005CA. This means that the terminals are not located in the same position on the new alternator. It is suggested that you mark each lead before removing it from the old alternator. Then connect to the appropriate terminal on the new alternator.

WIRE SIZE RECOMMENDATION	
TOTAL CIRCUIT LENGTH	WIRE SIZE
16 Feet or Less	No. 6
16-25 Feet	No. 4
25-40 Feet	No. 2

**PULLEY MOUNTING INSTRUCTIONS;** Pulley nut should be tightened to a torque of 40-50 lbs.

Important: The information contained in this bulletin is intended for use by trained, professional technicians who have the proper tools, equipment, and training to perform the required maintenance described above. This information is NOT intended for 'do-it-yourselfers'; and you should not assume that this information applies to your equipment. If you have any questions regarding this information please visit our website at [www.prestolite.com](http://www.prestolite.com), or contact our technical service department at: